

客户名称: 鑫源洋

VENDER:

承认书

SPECIFICATION FOR APPROVAL

物料编码

CUSTOMER P/N: _____

物料名称

MODEL NO: _____

高频变压器骨架

厂商料号

MANUFACTURER P/N: _____

BJ-EI-1303

供应商确认栏 / SUPPLIER APPROVED		客户承认栏 / CUSTOMER APPROVED	
拟制/DRAWN BY	吴威	确认/CONFIRM BY	
审核/CHECKED BY	邓书申	审核/CHECKED BY	
批准/APPROVED BY	徐伯刚	批准/APPROVED BY	
签章/ SIGNATURES:		签章/ SIGNATURES:	



深圳市铂骏电子有限公司

SHENZHEN PLATINUNJNUNELECTRONIC CO., LTD

地址: 深圳市宝安区福永街道桥头社区万延工业城 6 栋 4 楼 1 号

ADD: 1, 4/F, Building 6, wanyan industrial City, Qiaotou Community, Fuyong Town,
Bao'an District, Shenzhen, Guangdong

TEL: 0755-61183756

FAX: 0755-61183759

本承认书请在首批下单生产此机种前回签, 否则视为贵方默认此承认书内所有内容



深圳市铂骏电子有限公司

SHENZHEN PLATINUM JUNE ELECTRONIC CO., LTD

物料名称/MODEL NO:	BOBBIN(EI-1303)
版本/ REV:	A
发行日期 DATE:	2016-5-25

NO	MODIFY MATTER EXPLAIN	DATE	REV	PAGE
1	新订/ NEW			



1. MECHANICAL DIMENSION (UNIT:mm) 外形尺寸

ISSUE	DESCRIPTION	DATE
A	RELEASE FOR QUOTATION	16.01.26

型号 BJ-EI-1303

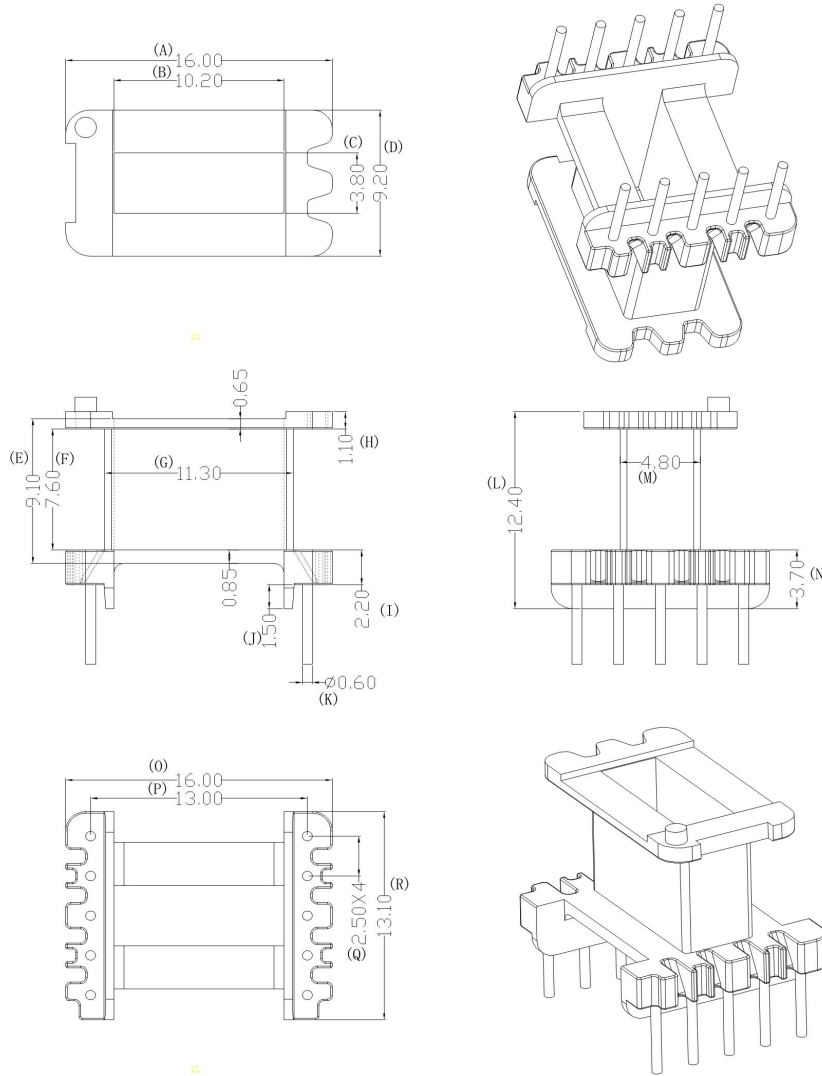

BOJUN 深圳市铂骏电子有限公司 深圳市福永街道桥头村富海工业区港华兴工业园第6栋4楼西		UNIT: MM		MODEL: EI-13 (5+5) PIN
		SCALE: 1/1		MATERIAL: PHENOLIC
TEL电话	(0755) 61183756-61183758	TOLERANCE 0<L≤4 ±0.1 4<L≤16 ±0.2 16<L≤50 ±0.3 50≤ ±0.4		DRWN BY: 刘文
FAX传真	(0755) 61183759			PIN PITCH: ±0.2 THICKNESS: ±0.15 ANGLE: ±1° PIN DIM: ±0.05
E-mail	1368426532@qq.com			APPROVED: 蒋艳



2. Appearance requirements/外观要求

- a. 无裂痕、无毛刺；
- b. 绕线处模具接痕光滑不刮手；
- c. 针脚光亮无氧化锈蚀，无露铜，歪斜等；
- d. 浸锡后产品无开裂，脚距排距需符合外形尺寸相关要求。

3、Materials Characteristics/使用材料的性能：

材质 Material	厂商 Manufacturer	UL NO	阻燃性 Flame retardant
T375J	长春	E59481	UL94 V-0
连续使用温度 Continuing Temp	引张强度 Tensile Strength	耐压测试 HI-POT TEST	结构强度 Structural strength
155℃	1.5Kgf/Sqmm	AC3500V/1mA/60S	1.0kgf

4、PIN-plated solder/镀锡 PIN 针

材质 Material	厂商 Manufacturer	UL NO	弯折次数 The number of bending
镀锡铜包钢线	宏达电子材料厂	-	≥3 次
抗拉强度 Tensile strength	附着强度 Adhesion strength	导电率 Conductivity	可焊性 Solderability
≥ 950N/mm ²	≥1.0kgf	23%	450℃ ± 20℃



深圳市铂骏电子有限公司
SHENZHEN PLATINUM JUNE ELECTRONIC CO., LTD

物料名称/MODEL NO:	BOBBIN(EI-1303)
版本/ REV:	A
发行日期 DATE:	2016-5-25

5.检查数据表

品 名	EI-1303		阻 燃 性		94V-0							
规 格	按照订单要求		检 验 数 量		10PCS							
材 质	T375J		检 验 标 准		依照 BOBBIN 成品检验标准							
尺 寸 测 量 分 布												
产品编号 尺寸代号	标准尺寸	1	2	3	4	5	6	7	8	9	10	
A	16.00±0.2	16.09	16.11	16.13	16.08	16.08	16.09	16.06	16.09	16.07	16.11	
B	10.20±0.2	10.21	10.18	10.17	10.16	10.16	10.20	10.18	10.17	10.19	10.25	
C	3.80±0.1	3.78	3.81	3.79	3.77	3.78	3.79	3.78	3.79	3.76	3.79	
D	9.10±0.2	9.14	9.08	9.06	9.11	9.13	9.12	9.10	9.08	9.09	9.07	
E	9.10±0.2	9.06	9.05	9.08	9.07	9.04	9.06	9.07	9.06	9.06	9.05	
F	7.60±0.2	7.57	7.58	7.59	7.55	7.54	7.57	7.55	7.59	7.55	7.57	
G	11.30±0.2	11.31	11.30	11.35	11.36	11.31	11.29	11.32	11.30	11.36	11.32	
H	1.10±0.1	1.07	1.06	1.05	1.08	1.08	1.09	1.07	1.09	1.11	1.12	
I	2.20±0.1	2.24	2.25	2.26	2.24	2.23	2.25	2.22	2.24	2.26	2.23	
J	1.40±0.1	1.39	1.41	1.38	1.36	1.41	1.41	1.42	1.36	1.38	1.45	
K	0.60±0.1	0.60	0.60	0.60	0.60	0.60	0.60	0.60	0.60	0.60	0.60	
L	12.40±0.2	12.50	12.49	12.52	12.55	12.51	12.51	12.48	12.49	12.45	12.44	
M	4.80±0.2	4.79	4.81	4.81	4.83	4.84	4.82	4.86	4.84	4.81	4.82	
N	16.00±0.2	15.98	16.04	15.96	16.03	15.98	16.00	15.99	16.05	16.01	15.99	
O	13.00±0.2	12.99	13.02	13.03	13.06	13.07	13.04	13.02	13.01	13.05	13.03	
P	2.50±0.1	2.51	2.52	2.48	2.50	2.52	2.48	2.49	2.48	2.53	2.52	
Q	13.10±0.2	13.17	13.18	13.16	13.14	13.15	13.16	13.15	13.09	13.11	13.16	
R												
S												
T												
U												
V												
W												
X												
Y												
Z												
耐压测试	电压: 3.5KV			电流: 1 MA			时间: 60S					
浸锡测试	温度: 400°C ± 20°C			时间: 1-3 S								
外观检验	变形	粘珠	氧化	毛边	残缺	破损	PIN歪	PIN穿	裂PIN	少针	混料	
	OK	OK	OK	OK	OK	OK	OK	OK	OK	OK	OK	

检验员: 薛宏丽

审核: 邓书申



深圳市铂骏电子有限公司
SHENZHEN PLATINUM JUNE ELECTRONIC CO., LTD

物料名称/MODEL NO:	BOBBIN(EI-1303)
版本/ REV:	A
发行日期 DATE:	2016-5-25

BOBBIN 焊锡前拉力测试表

产品型号		EI-1303				规 格		全插			料 号					
客户名称		鑫源洋				拉力标准		≥1.5kg			检验数量			14pcs		
孔号 模号	1	2	3	4	5	6	7	8	9	10	11	12	13	14	15	16
	1	1.76	1.78	1.69	1.78	1.77	1.79	1.63	1.55	1.82	1.74					
2	1.69	1.83	1.66	1.86	1.83	1.82	1.61	1.67	1.66	1.68						
3	1.66	1.82	1.73	1.77	1.71	1.79	1.64	1.75	1.66	1.52						
4	1.69	1.68	1.73	1.64	1.85	1.82	1.62	1.73	1.66	1.73						
5	1.75	1.77	1.66	1.63	1.69	1.82	1.55	1.78	1.63	1.67						
6	1.69	1.61	1.71	1.77	1.64	1.69	1.68	1.76	1.73	1.77						
7	1.78	1.89	1.83	1.66	1.67	1.62	1.62	1.81	1.66	1.69						
8	1.68	1.66	1.73	1.82	1.74	1.63	1.67	1.65	1.76	1.78						
9	1.88	1.82	1.65	1.66	1.68	1.73	1.67	1.57	1.69	1.83						
10	1.56	1.64	1.69	1.66	1.52	1.72	1.65	1.64	1.66	1.82						
11	1.69	1.66	1.82	1.66	1.73	1.72	1.62	1.58	1.69	1.68						
12	1.69	1.69	1.92	1.63	1.67	1.67	1.68	1.59	1.75	1.77						
13	1.64	1.66	1.71	1.73	1.77	1.77	1.72	1.69	1.69	1.61						
14	1.68	1.6	1.67	1.66	1.69	1.72	1.77	1.73	1.78	1.89						
15																
16																
17																
18																
19																
20																
21																
22																
23																
24																

审核：邓书申

检验员：薛宏丽

日期：2016-5-25



深圳市铂骏电子有限公司
SHENZHEN PLATINUM JUNELECTRONIC CO., LTD

物料名称/MODEL NO:	BOBBIN(EI-1303)
版本/ REV:	A
发行日期 DATE:	2016-5-25

BOBBIN 焊锡后拉力测试表

产品型号		EI-1303				规 格		全插			料 号					
客户名称		鑫源洋				拉力标准		≥2.0kg			检验数量			14pcs		
孔号 模号	1	2	3	4	5	6	7	8	9	10	11	12	13	14	15	16
1	2.27	2.52	2.39	2.61	2.37	2.35	2.24	2.52	2.50	2.38						
2	2.58	2.28	2.29	2.38	2.29	2.35	2.50	2.38	2.37	2.33						
3	2.42	2.51	2.57	2.66	2.42	2.37	2.37	2.33	2.33	2.42						
4	2.69	2.58	2.71	2.61	2.26	2.26	2.39	2.45	2.28	2.32						
5	2.59	2.55	2.59	2.43	2.27	2.36	2.45	2.32	2.22	2.34						
6	2.28	2.26	2.32	2.58	2.39	2.33	2.48	2.45	2.36	2.22						
7	2.46	2.49	2.53	2.34	2.24	2.52	2.29	2.48	2.45	2.34						
8	2.50	2.48	2.26	2.38	2.50	2.38	2.41	2.29	2.37	2.39						
9	2.37	2.39	2.42	2.35	2.37	2.33	2.47	2.48	2.29	2.27						
10	2.29	2.27	2.32	2.35	2.33	2.42	2.26	2.44	2.42	2.33						
11	2.42	2.33	2.34	2.37	2.28	2.32	2.52	2.22	2.26	2.28						
12	2.26	2.28	2.22	2.26	2.22	2.34	2.47	2.34	2.27	2.22						
13	2.27	2.22	2.34	2.36	2.36	2.22	2.26	2.38	2.39	2.36						
14	2.39	2.36	2.38	2.33	2.45	2.34	2.52	2.47	2.43	2.27						
15																
16																
17																
18																
19																
20																
21																
22																
23																
24																

审核：邓书申

检验员：薛宏丽

日期：2016-5-25